

NOTES:

- 1- USE BICYCLE SAFE GRATE ONLY UNLESS OTHERWISE APPROVED. SEE STANDARD DRAWING.
- 2- BOXES WITH PIPE SIZE GREATER THAN 15" DIAMETER AND BOXES GREATER THAN 4' IN DEPTH REQUIRE ENGINEERED DESIGN.
- 3- GRATES & FRAMES SHALL BE PAINTED WITH ONE COAT PRIMER AND ONE COAT LIGHT GREY FINISH. COATING APPLIED PER SPECIFICATIONS.

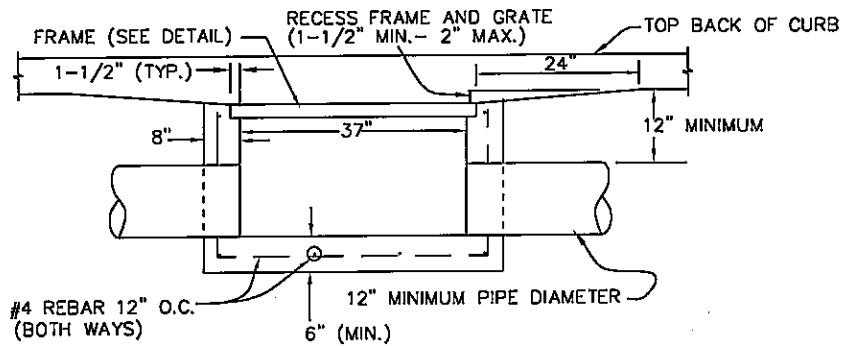
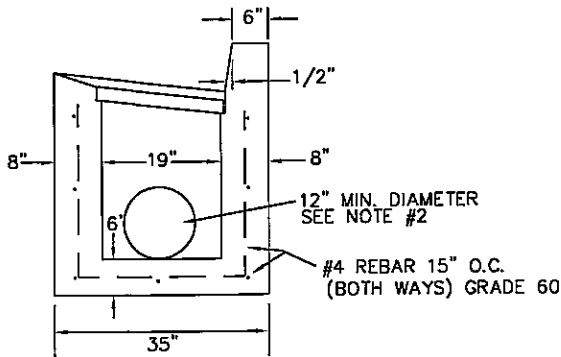
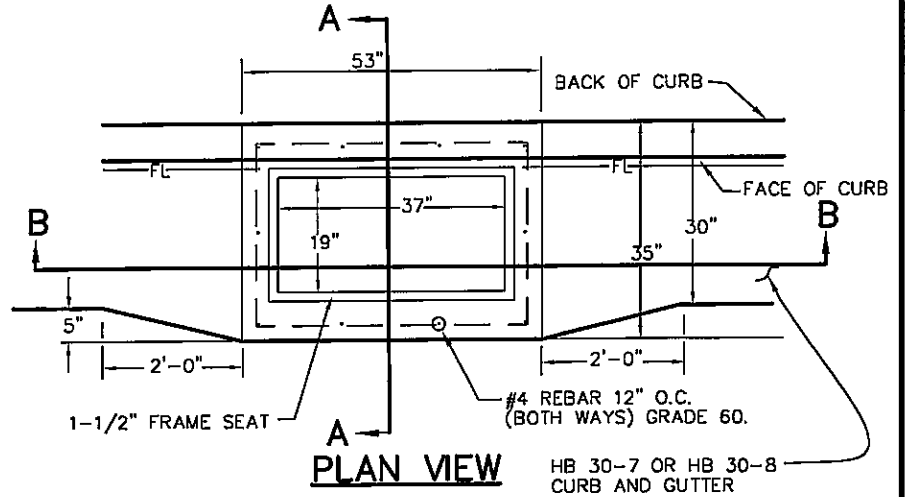

LONG DIMENSION OF BOX SHALL BE PARALLEL TO THE CURB & GUTTER.

SECTION B-B

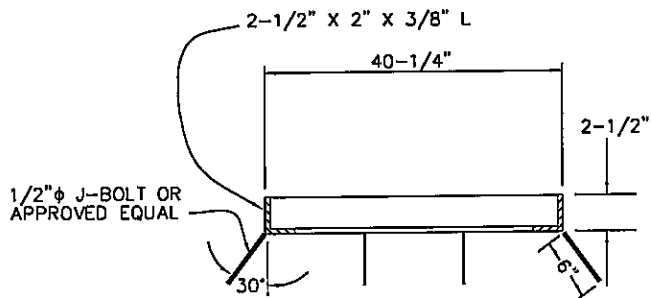
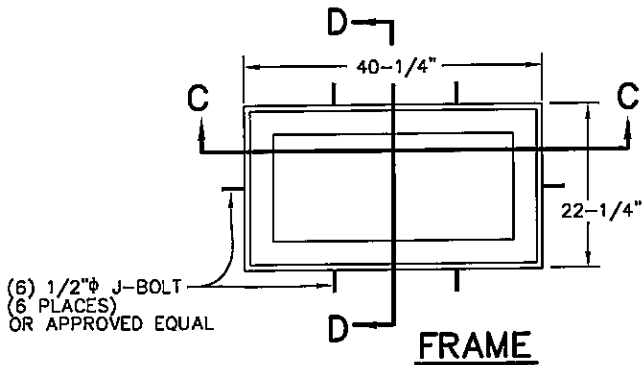

SECTION C-C

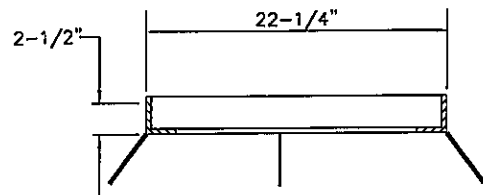

SECTION D-D

NO SCALE

CITY OF ST. GEORGE ENGINEERING DEPARTMENT

**STANDARD CATCH BASIN
 BOX & FRAME**

STANDARD DWG. NO.
 200 | 1 OF 1

REVISIONS		
DATE	DESCRIPTION	BY

APPROVED:
 DATE: | BY: LBB